

The GaGe Octopus™ family of multi-channel digitizers features up to 8 channels in a single-slot PCI card with up to 125 MS/s sampling per channel, and up to 4 GB of on-board acquisition memory. Combine several Octopus cards for up to 64 channels in a single system.

With more than 35 new digitizers to choose from, we offer you many more options than ever before.

## APPLICATIONS

Radar Design and Test  
Disk Drive Testing  
Manufacturing Test  
Signal Intelligence  
Lidar Systems  
Communications  
Non-Destructive Testing  
Spectroscopy  
High-Performance Imaging  
Ultrasound Test

## Octopus CompuScope 82XX

### 12-Bit Family of Multi-channel Digitizers for the PCI Bus



The Octopus family represents a new generation of GaGe digitizers that has all of the advanced features you would expect from a top performance signal capture card:

## FEATURES

- 2, 4, or 8 digitizing channels
- 10, 25, 50, 65, 100, or 125 MS/s sampling per channel
- 12 bits vertical resolution
- 128 MS to 2 GS on-board acquisition memory
- More than 100 MHz bandwidth
- Full-size, single-slot PCI card
- Full-featured front-end, with software control over input ranges, coupling and impedances
- 32 bits, 66 MHz PCI standard for 200 MB/s transfer to PC memory
- Ease of integration with External or Reference Clock In and Clock Out, External Trigger In and Trigger Event Out
- Programming-free operation with GageScope® oscilloscope software
- Software Development Kits available for LabVIEW, MATLAB, C/C#

## Octopus CompuScope 82XX Simplified Block Diagram

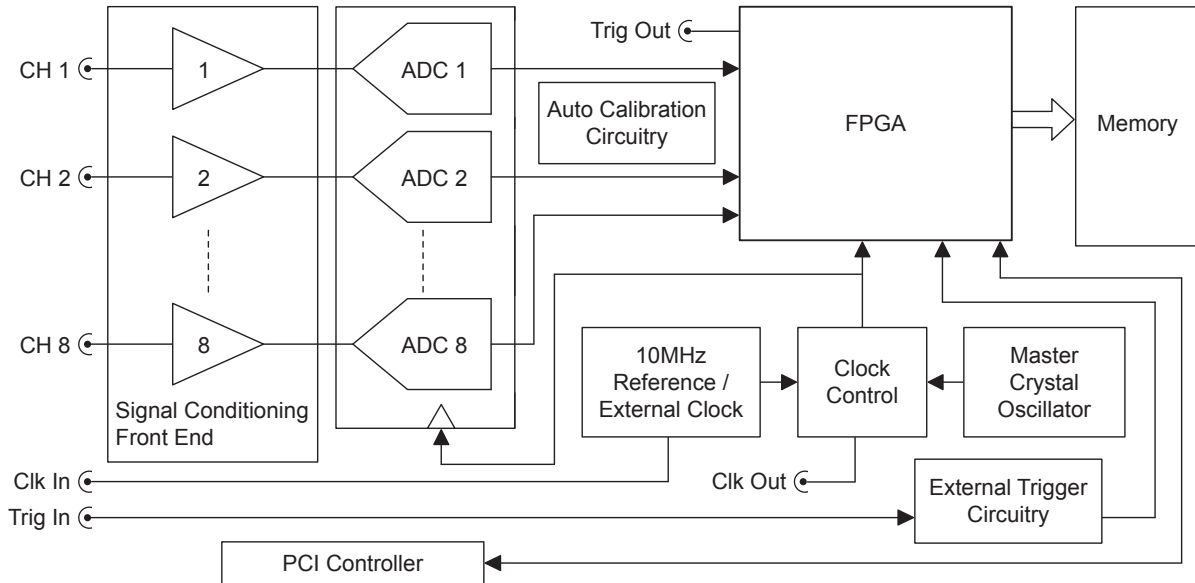

### A/D SAMPLING

Number of Inputs:	2, 4 or 8
Resolution:	12 bits
ENOB (see Note 1):	10.3 bits
SNR (see Note 1):	64 dB
SFDR (see Note 1):	79 dB
SINAD (see Note 1):	63.6 dB
Maximum Sampling Rate Per Channel (product-dependent):	10, 25, 50, 65, 100 or 125 MS/s
Sampling Rates:	125 MS/s, 105 MS/s, 100 MS/s, 80 MS/s, 65 MS/s, 50 MS/s, 40 MS/s, 25 MS/s, 20 MS/s, 10 MS/s, 5 MS/s, 2 MS/s, 1 MS/s, 500 kS/s, 200 kS/s, 100 kS/s, 50 kS/s, 20 kS/s, 10 kS/s, 5 kS/s, 2 kS/s, 1 kS/s
Connector:	SMB
Impedance:	1 M $\Omega$ or 50 $\Omega$ ; (software-selectable)
Coupling:	AC or DC; (software-selectable)
AC Coupled Bandwidth:	10 Hz to >100 MHz (see Note 2)
DC Coupled Bandwidth:	DC to >100 MHz (50 $\Omega$ see Note 5, slightly less for 1 M $\Omega$ )
Flatness (see Note 3):	Within $\pm 0.5$ dB of ideal response to 40 MHz
DC Accuracy (see Note 4):	$\pm 0.5$ %
Input Voltage Ranges:	$\pm 100$ mV, $\pm 200$ mV, $\pm 500$ mV, $\pm 1$ V, $\pm 2$ V, $\pm 5$ V, $\pm 10$ V ( $\pm 10$ V is only available in 1 M $\Omega$ )
DC Offset:	$\pm 1 \times$ Full Range (above $\pm 5$ V is limited to $\pm 2.5$ V)

### LOW-PASS FILTER

Type:	3-pole Bessel, 1 per channel
Cut-off Frequency:	24 MHz
Operation:	Individually software-selectable

### ACQUISITION MEMORY

Active Channels	Total On-board Memory				
	128 M	256 M	512 M	1 G	2 G
1	128 M	256 M	512 M	1 G	2 G
2	64 M	128 M	256 M	512 M	1 G
4	32 M	64 M	128 M	256 M	512 M
8	16 M	32 M	64 M	128 M	256 M

### TRIGGERING

Trigger Engines:	2 per channel, 1 for external trigger
Source:	CH 1 to 8, EXT or Software
Input Combination:	All combinations of sources logically OR'ed
Trigger Level Accuracy:	Less than $\pm 2\%$ of Full Scale for channel triggering
Slope:	Positive or Negative; software-selectable
Sensitivity:	$\pm 2\%$ of Full Scale This implies that signal amplitude must be at least 4% of full scale to cause a trigger to occur. Smaller signals are rejected as noise.
Post-Trigger Data:	128 points minimum. Can be defined with a 64 point resolution.
Maximum Record Length:	Maximum memory depth

### EXTERNAL TRIGGER

Impedance:	2 k $\Omega$
Amplitude:	Absolute maximum $\pm 15$ V
Voltage Range:	$\pm 1$ V, $\pm 5$ V (software-selectable)
Bandwidth:	>100 MHz
Coupling:	AC or DC
Connector:	SMB

## TRIGGER OUT

Impedance:	50 $\Omega$ compatible
Amplitude:	0-2.5 V
Connector:	SMB

## INTERNAL CLOCK

Accuracy:	$\pm 1$ ppm (0 to 50°C ambient)
-----------	---------------------------------

## EXTERNAL CLOCK

Maximum Frequency:	Maximum product sample rate
Minimum Frequency:	2 MHz
Signal Level:	Minimum 1 V RMS Maximum 2 V RMS
Termination Impedance:	50 $\Omega$
Sampling Edge:	Rising
Duty Cycle:	50% $\pm 5\%$
Connector:	SMB
Coupling:	AC

## EXTERNAL REFERENCE

The External Reference timebase is used to synchronize the Internal Sampling Clock

Frequency:	10 MHz $\pm 1000$ ppm; (software-selectable)
Signal Level:	Minimum 1 V RMS Maximum 2 V RMS
Impedance:	50 $\Omega$
Sampling Edge:	Rising
Duty Cycle:	50% $\pm 5\%$
Connector:	SMB

## CLOCK OUT

Maximum Frequency:	Maximum product sample rate
Minimum Frequency:	2 MHz (from External Clock) 1 kHz (from Internal Clock)
Signal Level:	0-2.5 V
Impedance:	50 $\Omega$ compatible
Duty Cycle:	50% $\pm 10\%$
Connector:	SMB

## MULTIPLE RECORD

Pre-trigger Data:	Up to virtually full record length
Record Length:	128 points minimum. Can be defined with a 64 points resolution.

## TIMESTAMPING

Resolution:	One sampling interval
Counter turnover:	>24 hours continuous

## CARD SIZE

Single-slot, full-length PCI

## SYSTEM REQUIREMENTS

PCI-based computer, minimum Pentium II 500 MHz, with at least one free full-length PCI slot, 128 MB RAM, 100 MB hard disk.

## COOLING SYSTEM

Minimum CFM Requirement: *Characterization in progress*

## †POWER (IN WATTS, PER CARD)

25.0 W (typical)

†Measured on a typical 4-channel Octopus card.

## PCI BUS INTERFACE

Plug-&-Play:	Fully supported
Bus Mastering:	Fully supported
Scatter-Gather:	Fully supported
Bus Width:	32 bits
Bus Speed:	66 MHz or 33 MHz
Bus Throughput:	200 MB/s to PC memory (66 MHz PCI; dependent on motherboard and number of PCI-PCI bridges)
Compatibility:	PCI-compliant, v.2.2 Also v.2.1 systems that supply 3.3 V to PCI slot

## MULTI-CARD SYSTEMS

Supported by all Octopus CompuScope models, GageScope, and SDKs.

## OPERATING SYSTEMS

Windows XP:	All Versions
Windows 2000:	SP1 or higher

## APPLICATION SOFTWARE

GageScope:	Windows-based software for programming-free operation
LITE Edition:	Included with purchase, provides basic functionality
Standard Edition:	Provides limited functionality of advanced analysis tools, except for Extended Math
Professional Edition:	Provides full functionality of all advanced analysis tools

## SOFTWARE DEVELOPMENT KITS (SDK)

CompuScope SDK for C/C# for Windows\*  
CompuScope SDK for MATLAB for Windows  
CompuScope SDK for LabVIEW for Windows

\*C/C# SDK is compatible with LabWindows/CVI 7.0+ compiler. Visual Basic.NET support available with purchase of C/C# SDK.

Contact your GaGe Sales Agent for information on Linux support.

## WARRANTY

One year parts and labor  
Certificate of NIST Traceable Calibration is included.

All specifications subject to change without notice.



**Notes to specifications:**

- 1) Measured at 125 MS/s in the ±500 mV range with 50 Ω input impedance using a 10 MHz sine wave with an amplitude of 95% of full scale and the on-board filtering capability.
- 2) 10 Hz at 1 MΩ only.
- 3) Measured at 125 MS/s in the ±500 mV range with 50 Ω input impedance with an amplitude of 95% of full scale.
- 4) Measured on ±500 mV, ±1 V, ±2 V input ranges for both 50 Ω and 1 MΩ input impedance settings.
- 5) Measured on ±1 V, ±2 V, ±5 V input ranges using the 50 Ω input impedance setting.

Unless otherwise specified, all dynamic performance specs have been qualified on engineering boards.

**ORDERING INFORMATION**

**Hardware & Upgrades**

Octopus 12-bit Family	2 Channel	4 Channel	8 Channel
10 MS/s	CS8220: OCT-822-000	CS8240: OCT-824-000	CS8280: OCT-828-000
25 MS/s	CS8222: OCT-822-002	CS8242: OCT-824-002	CS8282: OCT-828-002
50 MS/s	CS8224: OCT-822-004	CS8244: OCT-824-004	CS8284: OCT-828-004
65 MS/s	CS8225: OCT-822-005	CS8245: OCT-824-005	CS8285: OCT-828-005
100 MS/s	CS8227: OCT-822-007	CS8247: OCT-824-007	CS8287: OCT-828-007
125 MS/s	CS8229: OCT-822-009	CS8249: OCT-824-009	CS8289: OCT-828-009

Memory Upgrade: 128 MS to 256 MS	OCT-181-001
Memory Upgrade: 128 MS to 512 MS	OCT-181-003
Memory Upgrade: 128 MS to 1 GS	OCT-181-005
Memory Upgrade: 128 MS to 2 GS	OCT-181-007

36" SMB to BNC male cable	ACC-001-001
36" SMB to BNC male cable - 4 pack	ACC-001-003
6" SMB to BNC female cable	ACC-001-011
6" SMB to BNC female cable - 4 pack	ACC-001-013
6" SMB to SMB jumper cable	ACC-001-021
6" SMB to SMB jumper cable - 4 pack	ACC-001-023

**eXpert™ Firmware Options**

eXpert Signal Averaging Firmware Option	250-181-001
eXpert FIR Filtering Firmware Option	250-181-002
eXpert Peak Detection Firmware Option	250-181-003
eXpert Firmware Option bundle (Signal Averaging, FIR Filtering and Peak Detection)	888-100-026

**GageScope® Software**

GageScope: Lite Edition	Included
GageScope: Standard Edition (with Purchase of CompuScope Hardware)	300-100-351
GageScope: Professional Edition (with Purchase of CompuScope Hardware)	300-100-354

**Software Development Kits (SDKs)**

GaGe SDK Pack on CD	200-113-000
CompuScope SDK for C/C#	200-200-101
CompuScope SDK for MATLAB	200-200-102
CompuScope SDK for LabVIEW	200-200-103

900 N. State St.  
Lockport, IL 60441-2200

**Toll-Free (US and Canada):**  
phone 1-800-567-4243  
fax 1-800-780-8411

**Direct:**  
phone +1-514-633-7447  
fax +1-514-633-0770

**Email:**  
prodinfo@gage-applied.com

To find your local sales representative or distributor or to learn more about GaGe products visit:

**www.gage-applied.com**

Updated September 7, 2006

Copyright © 2006, 2007 Gage Applied Technologies. All rights reserved.