

The CompuScope 12400 PCI bus digitizer features 12-bit vertical resolution, 400 MS/s sampling, and high 200 MHz bandwidth.

The fast sampling rate enables the capture of high-speed signals with ultra-high timing precision. The high resolution allows the capture of signals with very high dynamic range.

Now available with up to 2 GS of on-board memory.

APPLICATIONS

Spectroscopy
Radar System Design and Test
Signal Intelligence
Lidar Systems
Communications
Ultrasonic Testing
High-Performance Imaging
Manufacturing Test

CompuScope 12400

General-purpose digitizer for the PCI bus



The CS12400 general-purpose digitizer features 12-bit vertical resolution and high sampling speed up to 400 MS/s.

FEATURES

- 400 MS/s sampling on one channel or 200 MS/s on 2 synchronous channels
- 12 bits nominal resolution
- 200 MHz bandwidth
- Full-size, single-slot PCI card
- Up to 2 Gigasamples of on-board acquisition memory
- Full-featured, software-controlled front-end
- 32 bits, 66 MHz PCI standard for 200 MB/s transfer to PC memory
- Compatible with GageScope oscilloscope software
- Software Development Kits available for LabVIEW, MATLAB, C/C#

CompuScope 12400 Simplified Block Diagram

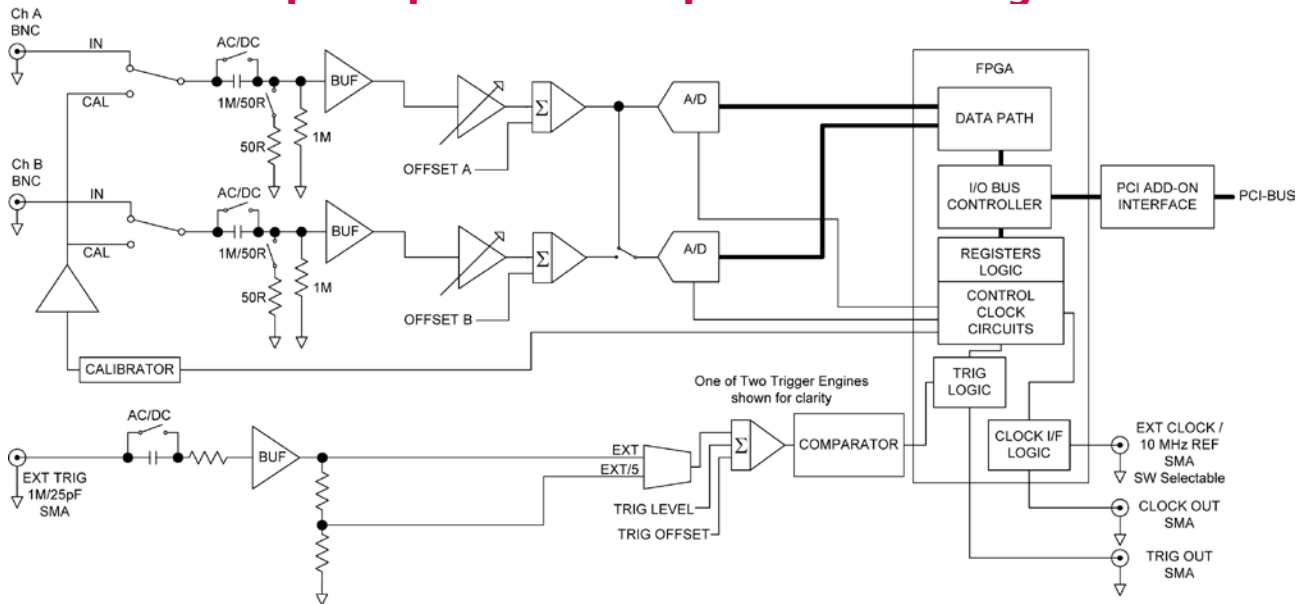

A/D SAMPLING

Number of Inputs:	2
Resolution:	12 bits
ENOB (see Note 1):	10.0 bits
SNR (see Note 1):	62.0 dB
SFDR (see Note 1):	72.0 dB
SINAD (see Note 1):	61.4 dB
Sampling Rates	
Channels A and B simultaneously:	200 MS/s, 100 MS/s, 50 MS/s, 25 MS/s, 20 MS/s, 10 MS/s, 5 MS/s, 2 MS/s, 1 MS/s, 500 kS/s, 200 kS/s, 100 kS/s, 50 kS/s
Channel A only:	400 MS/s, 200 MS/s, 100 MS/s, 50 MS/s, 25 MS/s, 20 MS/s, 10 MS/s, 5 MS/s, 2 MS/s, 1 MS/s, 500 kS/s, 200 kS/s, 100 kS/s, 50 kS/s
Connector:	BNC
Impedance:	1 MΩ 40 pF or 50 Ω; (software-selectable)
Coupling:	AC or DC; (software-selectable)
AC Coupled Bandwidth:	10 Hz to 200 MHz (see Note 2)
DC Coupled Bandwidth:	DC to 200 MHz (50 Ω only, slightly less for 1 MΩ, see Note 2)
Flatness (see Note 2):	Within 1 dB of ideal response over 75% of bandwidth
DC Accuracy:	±0.5 %
Input Voltage Ranges:	±100 mV, ±200 mV, ±500 mV, ±1 V, ±2 V, ±5 V (±5 V is only available in 50 Ω)
DC Offset:	± 1xFull Range, except in ±5 V input range
Protection:	with 1 MΩ impedance: Diode-clamped with 50 Ω impedance: No protection
Absolute Maximum Amplitude	
with 1 MΩ impedance:	±15 V (continuous)
with 50 Ω impedance:	±5 V (continuous); ±15 V (for 1 ms duration)

DIRECT-TO-ADC SAMPLING MODE

Mode Control:	Software-selectable
AC Coupled Bandwidth:	30 kHz to 170 MHz (50 Ω, AC only; see Note 2)
Range:	± 500 mV
Protection:	No protection
Absolute Maximum Amplitude:	± 2 V (continuous)
Sample Rate:	<=200 MS/s

ACQUISITION MEMORY

Data Storage:	In on-board memory
Dual-Channel Mode:	16M, 32M, 64M, 128M, 256M, 512M, 1G (12-bit samples in 16-bit words)
Single-Channel Mode:	Up to 2 GS (up to full on-board memory)

TRIGGERING

Trigger Engines:	2 per system
Source:	CH A, CH B, EXT or Software (software-selectable)
Input Combination:	1, 2, 1 or 2
Type:	Digital triggering on channels Analog triggering on external trigger
Trigger Level Accuracy:	±5% of Full Scale
Slope:	Positive or Negative (software-selectable)
Sensitivity:	±10% of Full Scale This implies that signal amplitude must be at least 20% of full scale to cause a trigger to occur. Smaller signals are rejected as noise.
Post-Trigger Data:	128 points minimum. Can be defined with a 64 point resolution.
Maximum Record Length:	Maximum memory depth

INTERNAL CLOCK

Source: Clock oscillator
Accuracy (0 to 50°C ambient): ±25 ppm for 200 MHz and lower
±50 ppm for 400 MHz

EXTERNAL TRIGGER

Impedance: 1 MΩ, 35 pF
Amplitude: Absolute maximum ±15 V
Voltage Range: ±1 V, ±5 V (software-selectable)
Bandwidth: 80 MHz
Coupling: AC or DC
Connector: SMA
Type: Analog Triggering

TRIGGER OUT

Impedance: 50 Ω
Amplitude: 0-2.5 V (TTL)
Connector: SMA

EXTERNAL CLOCK

Maximum Frequency: 420 MHz
Minimum Frequency: 40 MHz
Signal Level: Minimum 1 V RMS
Maximum 2 V RMS
Termination Impedance: 50 Ω
Sampling Edge: Rising
Duty Cycle: 50% ± 5%
Connector: SMA
Coupling: AC

EXTERNAL REFERENCE (OPTIONAL)

The External Reference timebase is used to synchronize the Internal Sampling Clock

Frequency: 10 MHz; (software-selectable)
Signal Level: Minimum 1 V RMS
Maximum 2 V RMS
Impedance: 50 Ω
Sampling Edge: Rising
Duty Cycle: 50% ± 5%
Connector: SMA

CLOCK OUT

Maximum Frequency: 200 MHz
Minimum Frequency: 40 MHz (from External Clock)
50 kHz (from Internal Clock)
Output Frequency: Equal to the sample rate when it is ≤ 200 MS/s
Equal to half the sample rate when it is > 200 MS/s
Signal Level: 0-2.5 V (TTL)
Impedance: 50 Ω
Duty Cycle: 50% ± 10%
Connector: SMA

TIMESTAMPING

Resolution: 7.5 ns
Counter turnover: 24 hours continuous

MULTIPLE RECORD

Pre-trigger Data: Up to virtually full record length
Record Length: 128 points minimum.
Can be defined with a 64 points resolution.
Maximum # of Triggers: 16,777,216

MULTI-CARD SYSTEMS

A unique feature of the CS12400 is its ability to automatically reconfigure itself to Master/Slave or Independent multi-card system simply by adding or removing the Master/Slave Timing Module.

Operating Mode: Master/Slave or Multiple/Independent configurations
Master/Slave: 2 to 8 cards
Multiple/Independent: Limited by PC backplane

CARD SIZE

Plugs into one full-length PCI slot, for all memory configurations

SYSTEM REQUIREMENTS

PCI-based computer, minimum Pentium II 500 MHz, with at least one free full-length PCI slot, 128 MB RAM, 100 MB hard disk, and SVGA video.

COOLING SYSTEM

Minimum CFM Requirement: *Characterization in progress.*

POWER (IN WATTS, PER CARD)

+5 V (all memory depths): 18.0 W (typical)
+3.3 V (all memory depths): 9.5 W (typical)
+12 V (all memory depths): 0 W (typical)
-12 V (all memory depths): 0 W (typical)

PCI BUS INTERFACE

Plug-&-Play: Fully supported
Bus Mastering: Fully supported
Scatter-Gather: Fully supported
Bus Width: 32 bit
Bus Speed: 66 MHz or 33 MHz
Bus Throughput: 200 MB/s to PC memory
(66 MHz PCI; dependent on motherboard and number of PCI-PCI bridges)
Compatibility: PCI-compliant v.2.2 systems. Also v.2.1 systems that supply 3.3 V to PCI slot

OPERATING SYSTEMS

Windows XP: All Versions
Windows 2000: SP1 or higher

APPLICATION SOFTWARE

GageScope: Windows-based software for programming-free operation
LITE Edition: Included with purchase, provides basic functionality
Standard Edition: Provides limited functionality of advanced analysis tools, except for Extended Math
Professional Edition: Provides full functionality of all advanced analysis tools



SOFTWARE DEVELOPMENT KITS (SDK)

CompuScope SDK for C/C# for Windows*
CompuScope SDK for MATLAB for Windows
CompuScope SDK for LabVIEW for Windows

*C/C# SDK is compatible with LabWindows/CVI 7.0+ compiler.
Visual Basic.NET support available with purchase of C/C# SDK.

Contact your Gage Sales Agent for information on Linux support.

WARRANTY

One year parts and labor
Certificate of NIST Traceable Calibration is included.

All specifications subject to change without notice.

Notes to specifications:

- 1) Unless otherwise specified, all dynamic performance specs (ENOB, SNR, SFDR, SINAD) are measured at 9.85 MHz with an Input Amplitude of 95% of Full Scale in Direct-to-ADC mode at 200 MS/s sampling on both channels.
- 2) Detailed characterization curves will be available upon request.

ORDERING INFORMATION

Hardware & Upgrades

CompuScope 12400-32M	124-001-002
CompuScope 12400-64M	124-001-003
CompuScope 12400-128M	124-001-004
CompuScope 12400-256M	124-001-008
CompuScope 12400-512M	124-001-005
CompuScope 12400-1G	124-001-006
CompuScope 12400-2G	124-001-007
CS12400: Memory Upgrades	Contact Gage
CS12400: Master Multi-Card Upgrade	124-181-002
CS12400: Slave Multi-Card Upgrade	124-181-003
CS12400: External Reference Clock Option	124-181-006

eXpert™ Firmware Options

eXpert Signal Averaging Firmware Option	250-181-001
eXpert FIR Filtering Firmware Option	250-181-002
eXpert Peak Detection Firmware Option	250-181-003
eXpert Firmware Option bundle (Signal Averaging, FIR Filtering and Peak Detection)	888-100-026

GageScope® Software

GageScope: Lite Edition	Included
GageScope: Standard Edition (with Purchase of CompuScope Hardware)	300-100-351
GageScope: Professional Edition (with Purchase of CompuScope Hardware)	300-100-354

Software Development Kits (SDKs)

Gage SDK Pack on CD	200-113-000
CompuScope SDK for C/C#	200-200-101
CompuScope SDK for MATLAB	200-200-102
CompuScope SDK for LabVIEW	200-200-103

All Upgrades performed at the factory.

900 N. State St.
Lockport, IL 60441-2200

Toll-Free (US and Canada):

phone 1-800-567-4243
fax 1-800-780-8411

Direct:

phone +1-514-633-7447
fax +1-514-633-0770

Email:

prodinfo@gage-applied.com

To find your local sales representative
or distributor or to learn more about
Gage's products visit:

www.gage-applied.com

Updated July 24th, 2006

Copyright © 2005, 2006 Gage Applied Technologies. All rights reserved.